

Time Projection Chamber for Measurements of the Density Dependence of Symmetry Energy and the Isospin Dependence of the Nuclear EoS

- 1) What is the primary physics motivation and experimental capability of the proposed instrument and why is this important for FRIB science?

One of the future directions in FRIB physics is to understand the “nature of neutron stars and dense nuclear matter”, a goal that requires understanding the Equation of State (EoS) for neutron-rich matter. This requires measuring the density dependence of the symmetry energy at supra-saturation densities. Besides its fundamental importance to the understanding of nuclei and nuclear matter, experimental information about the EoS can help to provide improved predictions for neutron star observables such as stellar radii and moments of inertia, crustal vibration frequencies, and neutron star cooling rates that are currently being investigated with ground-based and satellite observatories.

Calculations predict that the relative concentrations of neutrons and protons in the dense interior of a central nucleus-nucleus collision reflect the pressure of the symmetry energy. The symmetry potential energy generates forces that are of opposite sign for neutrons and protons and pressures that are greater for a “stiffer” symmetry energy term with stronger density dependence. Calculations predict that comparisons of positive and negative pion production and flows in $^{132}\text{Sn}+^{124}\text{Sn}$ and $^{108}\text{Sn}+^{112}\text{Sn}$ collisions provide sensitivity to the symmetry energy and can provide constraints on its density dependence. Complementary studies can also be obtained from comparisons of the production and flows of tritons and ^3He 's and neutrons and protons.

An experimental program to probe the symmetry energy at supra-saturation densities can be accomplished by running the ATTPC as a Time Projection Chamber (TPC) in the S2 vault, where it can receive fast fragmentation beams. This placement would also allow complimentary studies of the excitation of giant resonances of rare isotopes, which also provide information about the symmetry energy and measurements of the fission barriers of rare isotopes, which can improve extrapolations of fission barriers towards nuclei relevant to the r-process. These latter two studies require running the ATTPC as an active target with fast beams.

- 2) What are the unique capabilities of this device that are not available in existing equipment? Is this instrument stand alone or is it to be used (solely or partially) in conjunction with other instruments. Could it be used at NSCL or other laboratories before FRIB?

The ATTPC supports a broad experimental program that includes nuclear structure and astrophysics measurements with reaccelerated beams, as well as the measurements with fast beams mentioned in response to question #1. For measurements relevant to the symmetry energy, a scintillator array will provide an external trigger. The giant resonance measurement will use the ATTPC as a standalone device. Isotopically resolved fission fragment measurements will require detection of the fission fragments in ancillary silicon telescopes. The ATTCP is under construction and will begin operations at the CCF well before the completion of FRIB. There are no current plans to move it to other facilities before the completion of FRIB.

As the ATTPC is currently being constructed, the main purpose of this document is to highlight the importance of using the ATTPC with fast beams and indicate that these measurements require its placement in a vault served by fast fragmentation beams such as S2.

- 3) Describe the instrument in some detail – how does it meet the scientific requirements and what are the (estimated) performance specifications? Be brief but as detailed as you can. Is the design fixed or are multiple options still being discussed and encouraged?

The ATTPC is a solenoidal TPC approximately 70 cm in diameter and 120 cm in length.

It fits into the TWIST solenoid, allowing momentum analysis of emitted particles. Track information will be read out with approximately 10000 pads, using active target readout electronics that are currently under development.

- 4) What is the current stage of development of your project?

Micromegas and GEM readout schemes have been tested with prototype electronics and a wire read out scheme will be tested soon. Final decisions about the readout technology will be made this spring and it is planned that a prototype of the ATTPC will be completed this summer, with experiments to be conducted this autumn.

- 5) What is the approximate cost of the project: discuss possible sources of funding.

The ATTPC is funded with a budget of approximately 1 million dollars, provided by the NSF and Michigan State University.

- 6) Please provide a brief list of collaborators and institutions. Spokesperson(s) provide contact info. There are two groups of collaborators.

On the ATTPC project, we currently have:

Abigail Bickley, William Lynch, Wolfgang Mittig, Fernando Montes and Gary Westfall - Michigan State University

Michael Famiano - Western Michigan University

Umesh Garg, James Kolata - University of Notre Dame

Michael Heffner - Lawrence Livermore Laboratory

Ritu Kanungo - St. Mary's University

I. Yang Lee, Larry Phair - Lawrence Berkeley Laboratory

ATTPC project leader Wolfgang Mittig - Mittig@nscl.msu.edu, (517) 333-6329

On the symmetry energy measurements, we currently have:

Abigail Bickley, William Lynch, Manyee Betty Tsang, Gary Westfall - MSU

Michael Famiano – Western Michigan University

Sherry Yennello – Texas A&M University

Michael Lisa – Ohio State University

Tetsuya Murakami – Kyoto University-Japan

Wolfgang Trautmann – GSI, Germany

Roy Lemmon – Daresbury Laboratory, United Kingdom

Giuseppe Verde, Angelo Pagano, Paulo Russotto – INFN Catania, Italy

Abdou Chbihi, John Frankland, Jean-Pierre Wieleczko – GANIL, France

Shunji Nishimura, Yoichi Nakai, Atsushi Taketani - RIKEN, JP:

Jiro Murata, Kazuo Ieki - Rikkyo University, JP:

Yvonne Leifels, Marcus Bleicher - GSI DE:

Symmetry Energy Project spokesperson – Manyee Tsang - Tsang@nscl.msu.edu, (517) 333-6386.

- 7) Please can you outline how your collaboration has been developing your project and how you are growing your collaboration (How many meetings? Participants? Circular mailings? Have you a web-site?)

The AT-TPC collaboration formed in 2007 to develop the proposal for the ATTPC. The web site for the ATTPC collaboration is at: <http://groups.nscl.msu.edu/tpc/wiki/doku.php>, where a list of workshops and collaboration meetings for the AT-TPC can be found. Electronics development

for the ATTPC is conducted by the GET collaboration, which held its most recent collaboration meeting at Crepon, France during January 11-15, 2010.

The Symmetry Energy project was formed in 2008 to develop and submit proposals for a broad range program to measure the symmetry energy at supra-saturation densities. Members of this collaboration submitted successful proposals for this research to the CCF, RIKEN, and GSI program advisory committees and to the U.S. Department of Energy. A meeting of this collaboration was held in Catania in November 8, 2009. Additional meetings are scheduled for February 19, 2010 and later in July of this year.

- 8) Did you consider alternative designs? What alternatives were considered? How did you arrive at a final design?

We considered both dipole and solenoidal designs for the magnetic field. Simulations of the performance of the ATTPC for structure and reactions programs with CCF and FRIB beams led to the selection of the solenoidal design to be the one best suited to the beam energies available at these facilities. The choice between wires or micromegas readout technologies is still underway. The ATTPC readout electronics is being developed to be self triggering, which is essential for the active target part of its experimental program. The design is not completely final but will be finalized this year.

- 9) What existing equipment exists in the US Community that has similar goals and characteristics, even if inferior in performance.

TPC's exist in the U.S. at BNL, Fermi-Lab, and Jefferson Laboratory, but none are easily adapted to function as an active target. Some active targets exist, but none have the resolution or granularity of the ATTPC.

ATTPC: Drawing

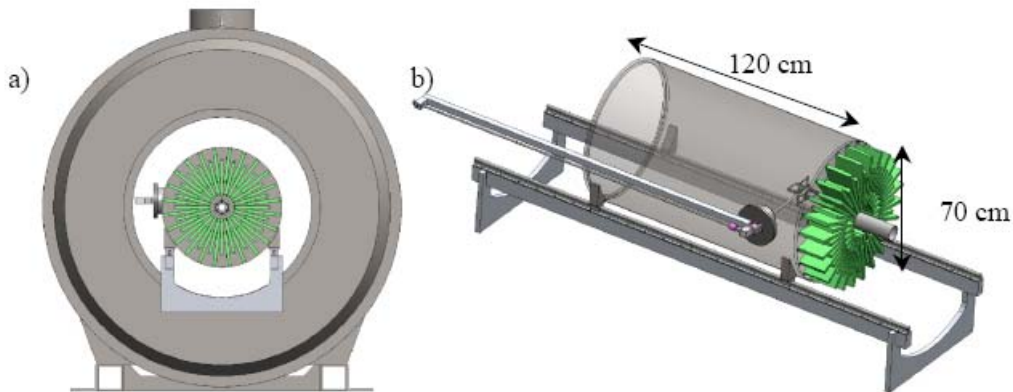

Figure 1: Design of the proposed active target time projection chamber: a) installed within the solenoid; b) view of chamber with removable target wheel.

Proposed ATTPC location for fast beams:

