



Today

- Announcements:
 - HW#5 is due by 8:00 am Wednesday February 20th.
 - The third extra credit problem is also due Feb 20 at 8:00am. This is a super bonus problem.
- Temperature
- Second Law of Thermodynamics



C.P. Snow – Lecture on the *Two Cultures* 1959

Two Cultures: Humanities and the Sciences

There is a danger if the two can not understand each other.

Paraphrase of a famous quote: Not knowing what the second law of thermodynamics means is the equivalent of never having read Shakespeare.

“I now believe that if I had asked an even simpler question — such as, What do you mean by mass, or acceleration, which is the scientific equivalent of saying, 'Can you read?' ... So the great edifice of modern physics goes up, and the majority of the cleverest people in the western world have about as much insight into it as their Neolithic ancestors would have had.”

Clicker Questions: Bead on a wire

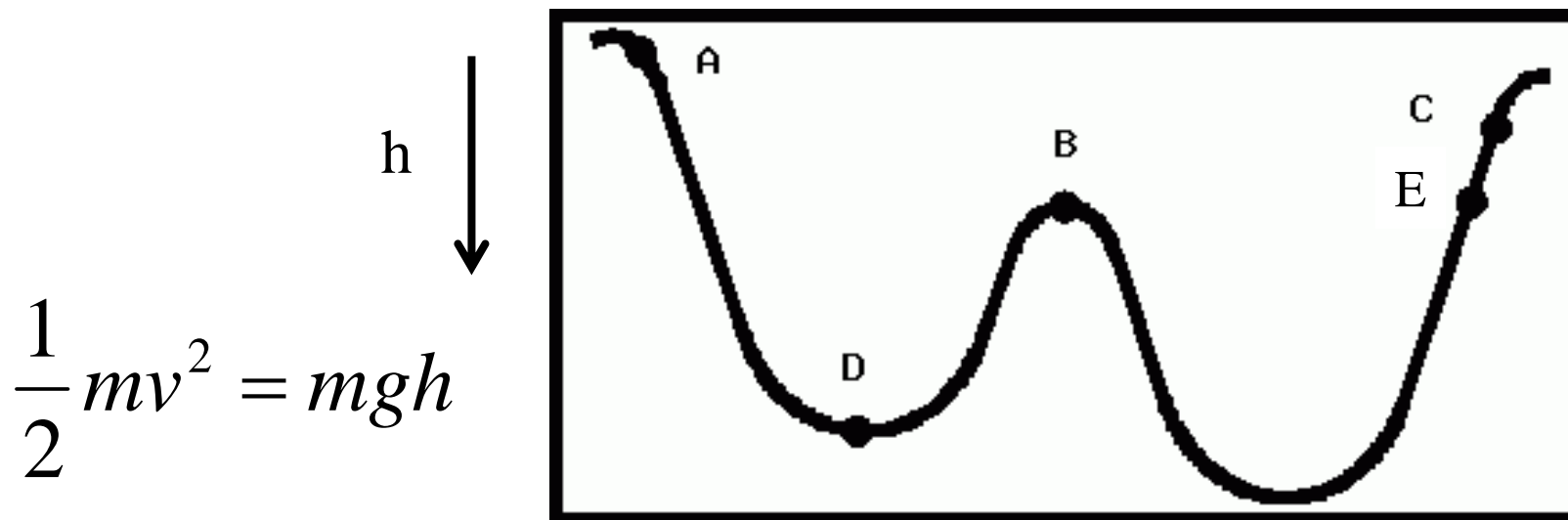

$$\frac{1}{2}mv^2 = mgh$$

Where is the potential energy the highest?

Where is the kinetic energy the highest?

Where is the speed the same as E?

What direction is the acceleration at B? Hint: the track is circular.

A) Down B) Up C) Left D) Right



Time Travel

- Einstein's theory of General Relativity explains the origin of gravity by mass distorting space-time
- Time is a dimension in a 4-dimensional universe
- If time is a dimension like the other three, can we move back and forth in time? Why does time have a direction? Arrow of time
- If we can travel back in time, it would be possible for us to influence things so that we are not born.
- Three theories to resolve the paradox
 - Travel back in time is not possible
 - There are a very large number of parallel universes
 - Something about nature prevents us from influencing the past

What is Temperature?

Old definition:
Temperature is the thing
measured by thermometers.

$$^{\circ}\text{F} = (9/5) ^{\circ}\text{C} + 32$$

$$\text{K} = ^{\circ}\text{C} + 273.1$$

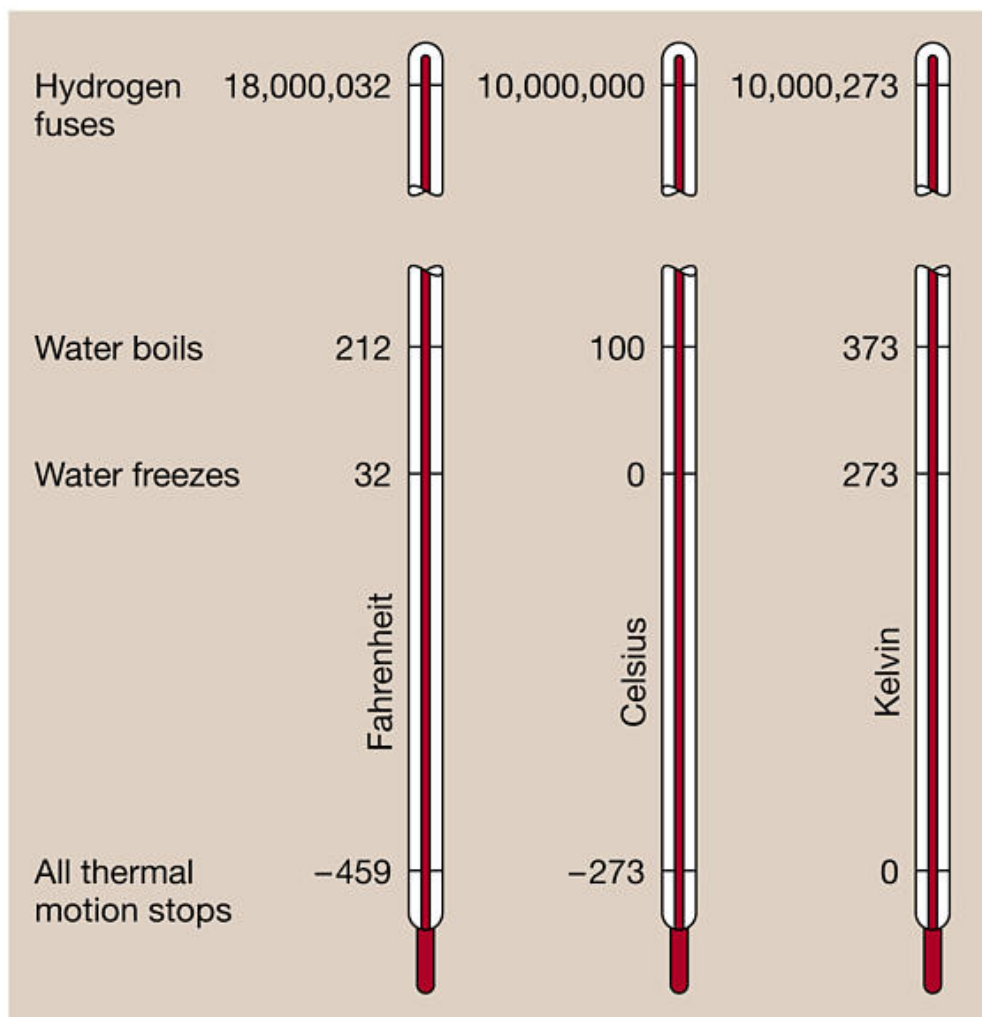



What is Temperature?

- Modern Idea: Temperature is a measure of the average kinetic energy of molecules – higher T more motion. This is called the Kinetic Theory of Gasses
- Actually, each molecule in a gas has a range of kinetic energies. Boltzmann Distribution
- Illustration: <http://celiah.usc.edu/collide/1/>
- Average kinetic energy of a gas molecule

$$KE = \frac{1}{2}mv^2 \quad KE_{average} = \frac{3}{2}k_B T \quad k_B = 1.38 \times 10^{-23} \frac{J}{K}$$



The distribution depends on temperature

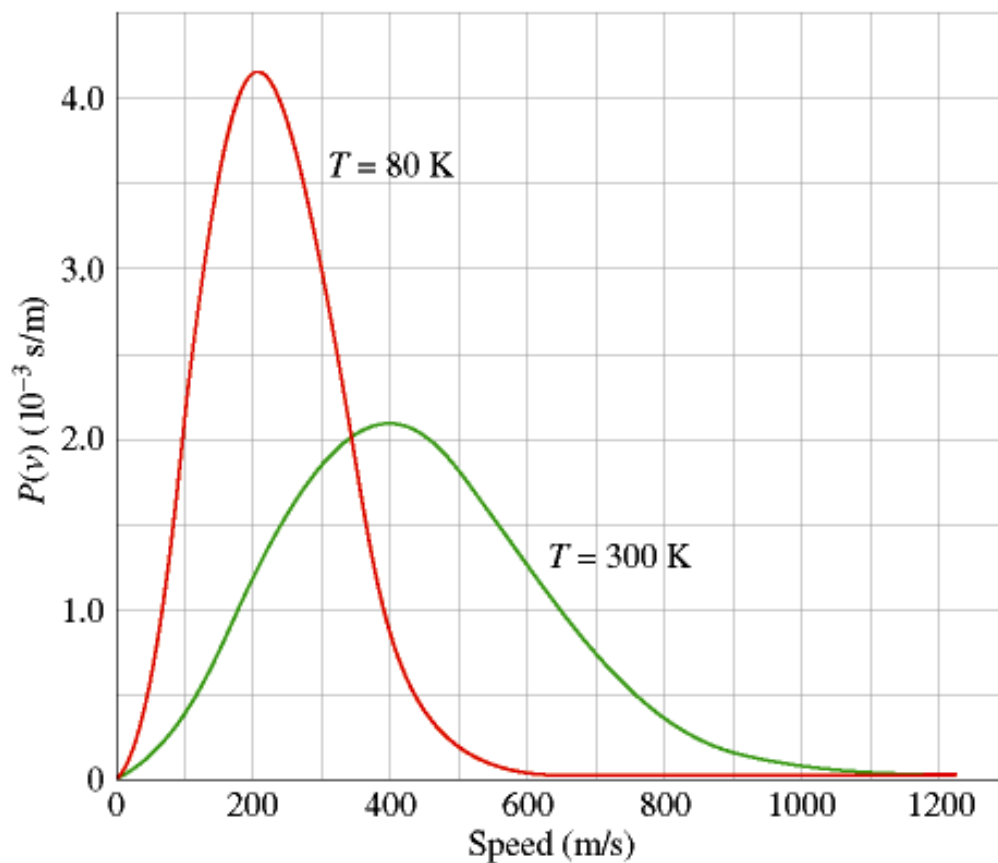

N_2 molecules

Boltzmann Distribution – Different masses

Maxwell-Boltzmann Molecular Speed
Distribution for Noble Gases

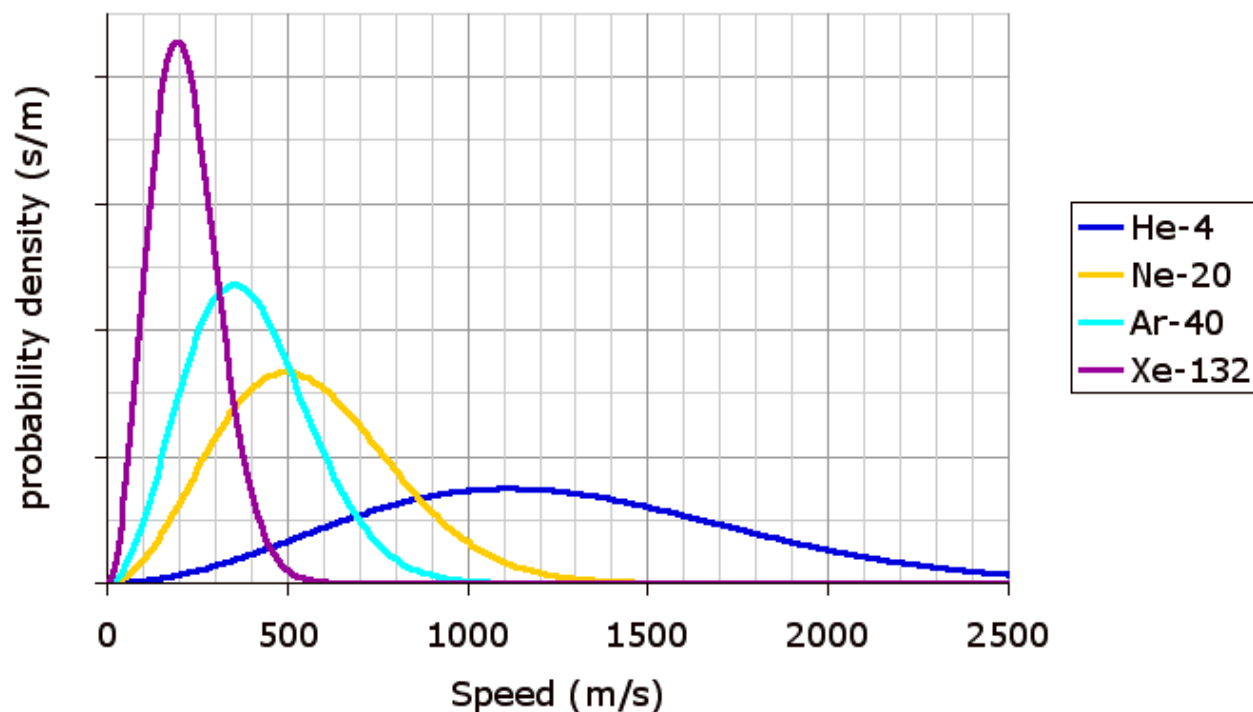

All molecules have the same average kinetic energy.

Larger mass means less velocity.

Distribution of Noble gas speeds at 25 C.



Energy in air

What is the energy content in 22.4 l of air at room temperature?

DATA: $T_{\text{room}} = 300 \text{ K}$

To make this simple, lets assume air is all N_2 .

22.4 l is one mole or $6.022\text{E}23$ atoms

$$\text{Energy} = N \cdot \frac{3}{2} k_B T = 6.022 \times 10^{23} \cdot \frac{3}{2} \cdot 1.38 \times 10^{-23} \cdot 300$$

$$\text{Energy} = 3739. \text{ J}$$

Energy Flow Diagrams

We can represent the conservation of energy by a diagram:

Book sliding across the table

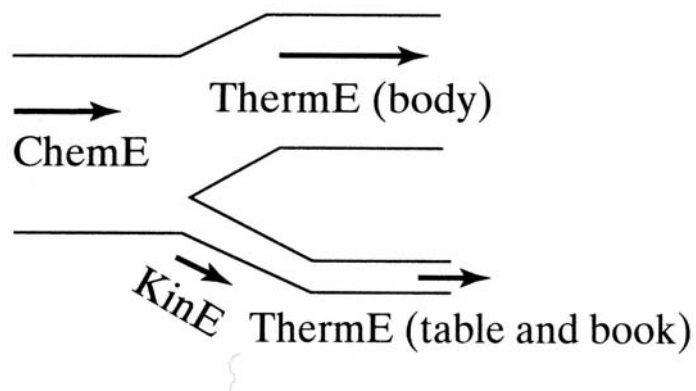

$$Kcal = \text{heat} + \frac{1}{2} mv^2$$

A book falls off table and hits the floor

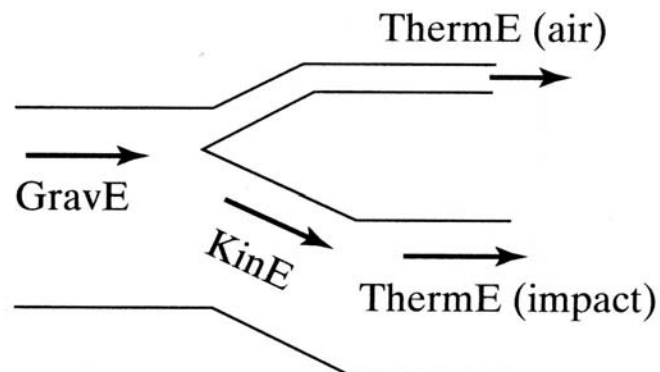

$$mgh = \text{heat} + \frac{1}{2} mv^2$$

Energy Flow Diagram

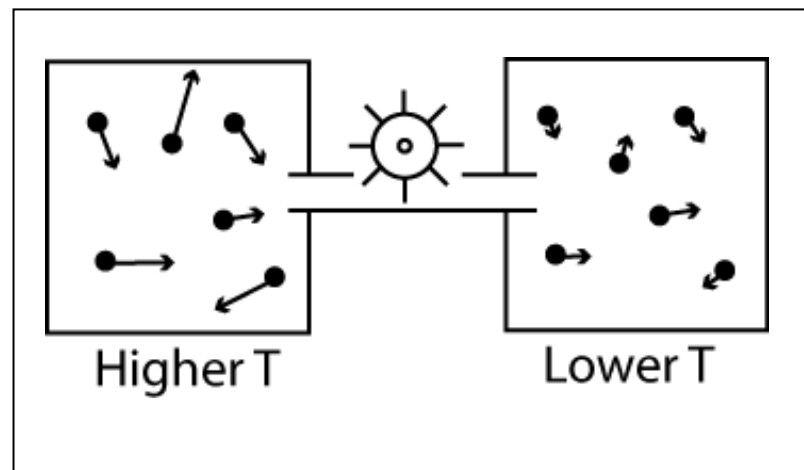
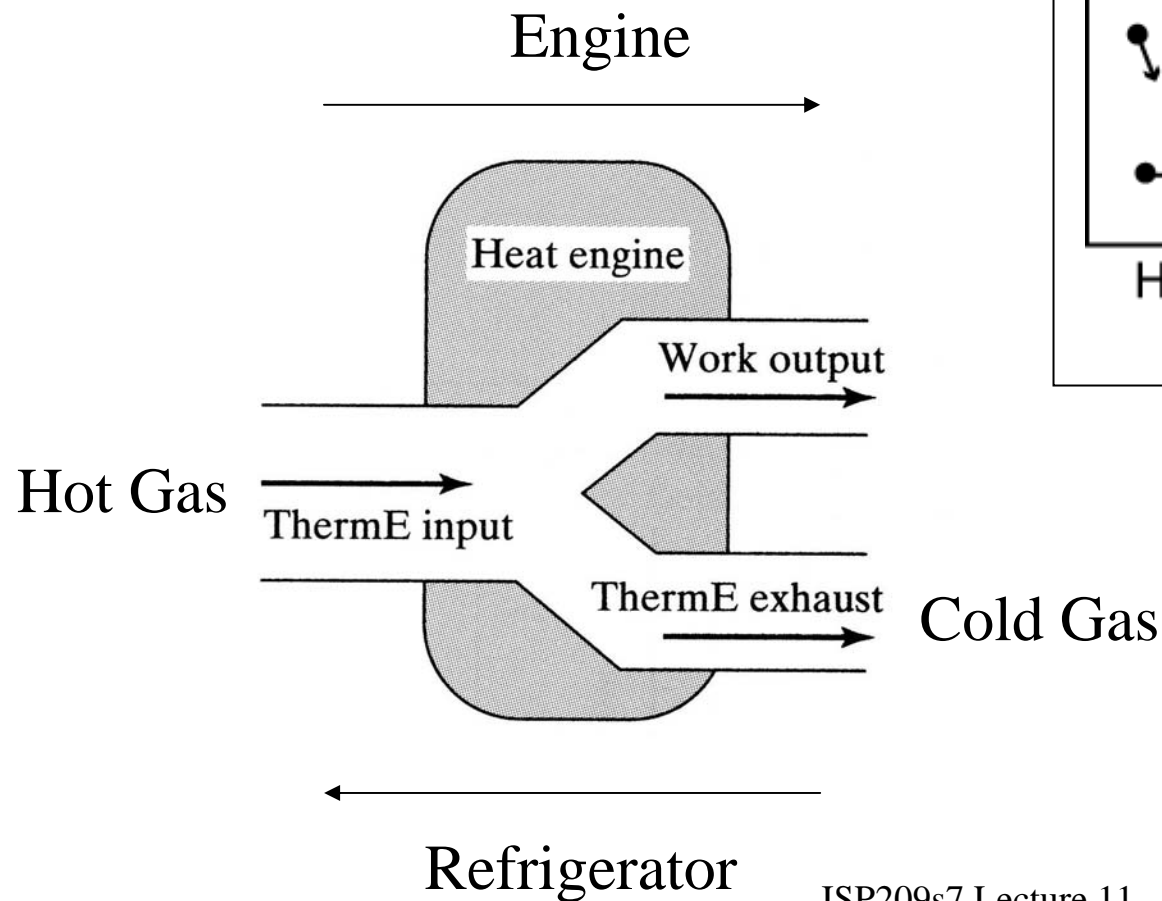

Picture

Heat Engine used to produce work

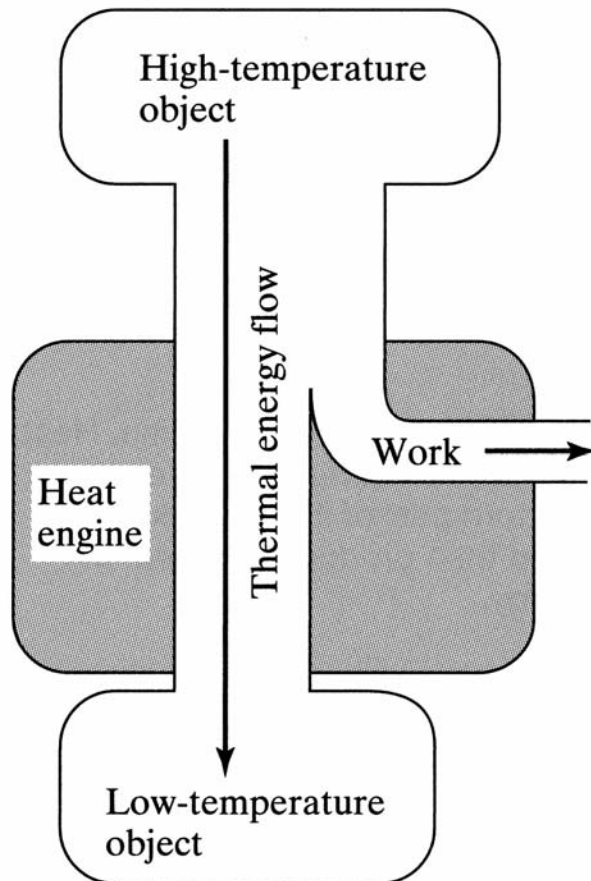

$$\text{efficiency} = \frac{T_{hot} - T_{cold}}{T_{hot}}$$

T must be measured in Kelvin.

Power plants are more efficient if they can discharge their heat at colder temperature.

Typical Energy Flow Diagram for a Car

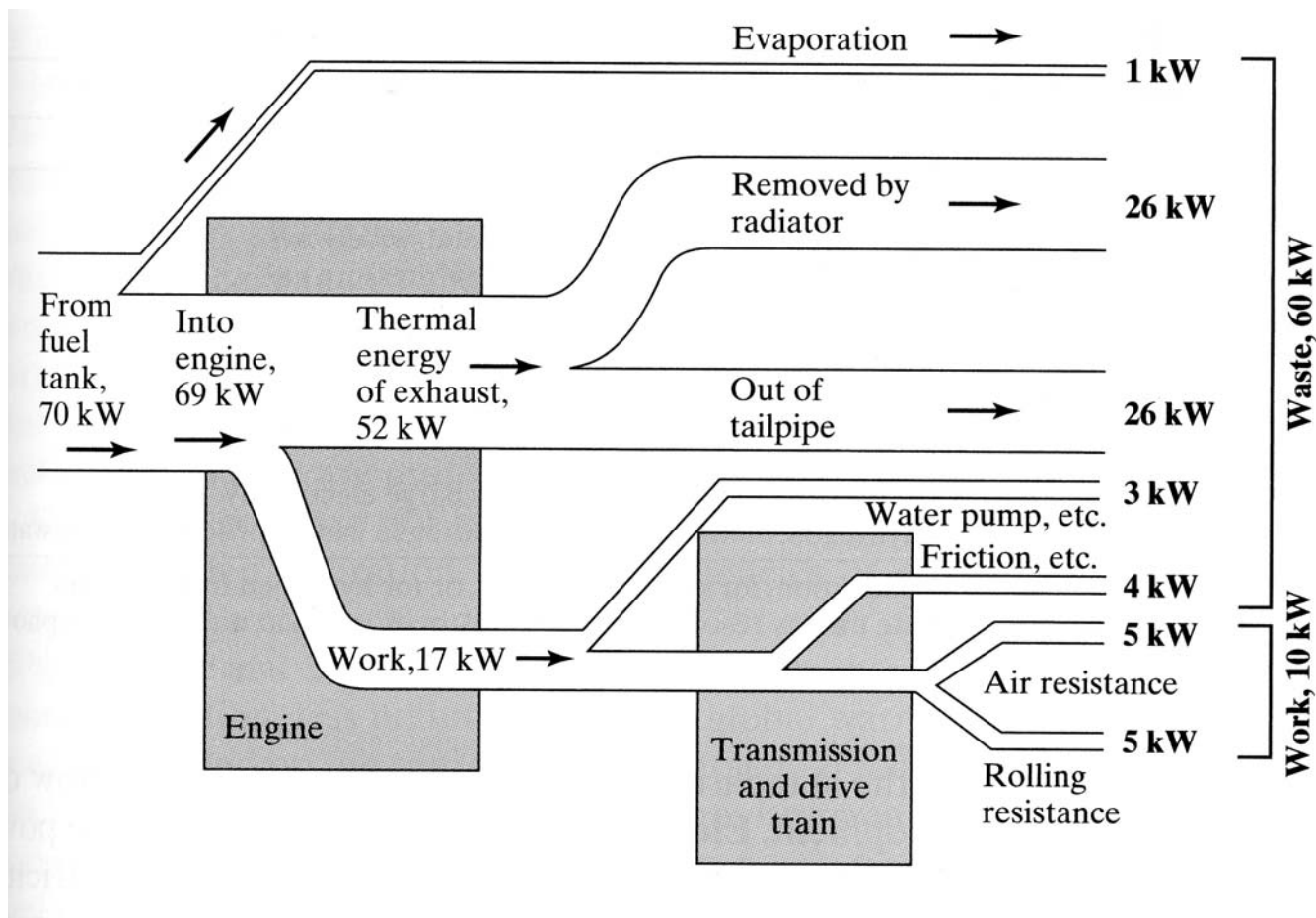

Could we recover waste heat?

Could we take energy out of a colder system and do work?

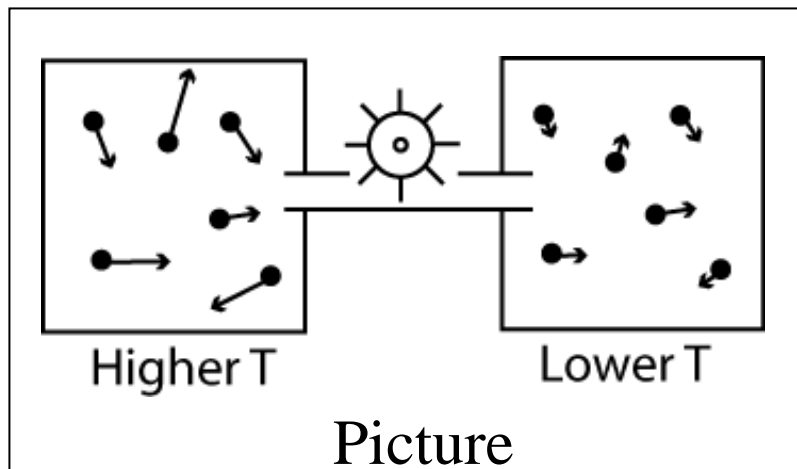

Take all the energy

And put it here



Second law of thermodynamics: No system can completely transform a given amount of heat into work.



Entropy

- Entropy is a measure of the number of ways a system can be arranged. We usually use the symbol S .
- Entropy is not a measure of disorder!
- The unit is J/K (*joules/Kelvin*)
- Formula: $S = k \ln(W)$, where $k=1.38E-23 J/K$ and W is the number of possible states of a system.
- Alternative formula: $S = \text{heat/temperature}$



The Second Law of Thermodynamics

- Statement: No device can transform a given amount of heat completely into work.
- Modern way to say this: The entropy of an isolated system never decreases.
- Natural process tend to move toward a state of greater disorder.
- Consequence: Time appears to have a direction.



The Three Laws of Thermodynamics

Thermodynamics is the study of the inter-relation between heat, work and energy of a system.

The British scientist and author C.P. Snow had an excellent way of stating the three laws:

- 1st Law: Energy is conserved. You cannot win (that is, you cannot get something for nothing, because matter and energy are conserved).
- 2nd Law: You cannot break even (you cannot return to the same energy state, because there is always an increase in disorder; entropy always increases).
- 3rd Law: You cannot get out of the game (because absolute zero is unattainable).



Two examples

What is the entropy of a deck of cards that has one pair?
Data: there are 1,098,240 ways to order such a deck.

$$S = 1.38E-23 \text{ J/K} \ln(1,098,240) = 1.92E-22 \text{ J/K}$$

How much is the entropy of a glass of water increased if
1.0 J of heat is added when the water is at 295 K.
Assume the temperature rise of the water is small.

$$S = 1.0 \text{ J} / 295 \text{ K} = 3.39E-3 \text{ J/K}$$



Coin Tosses

- Suppose we have 20 coins: HHHHHHHHHH
 $S = k \ln(1) = 0$

| Heads | Number of ways | Entropy (J/K) * 10^{-23} |
|-------|----------------|----------------------------|
| 9 | 10 | 3.18 |
| 8 | 45 | 5.25 |
| 7 | 120 | 6.61 |
| 6 | 210 | 7.38 |
| 5 | 252 | 7.63 |
| 4 | 210 | 7.38 |
| 3 | 120 | 6.61 |
| 2 | 45 | 5.25 |
| 1 | 10 | 3.18 |



Why does time always move in one direction?

- The Universe was created with very low entropy. Much too low for its size. It is like the Universe started with all heads.
- Hence, everything in the Universe moves toward reaching the correct amount of entropy. It is very improbable to go the other way. In this case very means so improbably that it never happens.
- Time has a direction because going back in time would imply the entropy could be decreased. That is very improbable.
- The Universe tends toward increasing entropy.